

Name: _____

Student #: _____ Section: _____

York University

Faculty of Science and Engineering
Department of Computer Science and Engineering

CSE1520.03 - Computer Use: Fundamentals

Winter 2006 Final Examination

Sunday, April 9, 2006

Instructions:

1. York University examination rules are in effect.
2. **Answer ALL questions by filling in the appropriate letters on the answer sheet provided using an HB / No. 2 pencil.**
 - **Your answers are machine marked so be sure to fill in the bubbles very carefully.**
 - **Also circle your answers on the examination paper as backup.**
3. **No aids allowed.** In particular, the use of calculators is **NOT** permitted.
4. There are 22 pages (including cover page) with 100 equally-weighted questions. Check that your question paper is complete.
5. Time allowed is 3 hours.
6. **Be sure your ID is coded correctly on the Scantron sheet**
7. **Both** the question sheets and the answer sheet **must be submitted together.**

EXCEL FUNCTION LIST

SUM (range)
MIN (range)
MAX (range)
AVERAGE (range)
MEDIAN (range)
SIN (number)
TAN (number)
COS (number)
PI ()
COUNTIF (range, criteria)
RAND ()
ROUND (number, num_digits)
ROUNDUP (number, num_digits)

IF (logical_test, value_if_true, value_if_false)
AND (logical1, logical2, ...)
OR (logical1, logical2, ...)
NOT (logical)
TRUE ()
FALSE ()
LEFT (string, number_of_characters)
RIGHT (string, number_of_characters)
MID (string, start_char, num_chars)
STDEV (number1, number2, ...)
LOOKUP (lookup_value, lookup_vector, result_vector)

YEAR (serial_number)

NOW ()
TODAY ()
COUNTIF (range, criteria)
SUMIF (range, criteria, sum_range)
VLOOKUP (lookup_value, table_array, col_index_num, range_lookup)
HLOOKUP (lookup_value, table_array, row_index_num, range_lookup)
MATCH (lookup_value, vector)

MOD (number, divisor)
INT (number)
INDEX (array, row_num, col_num)

1. This person played a key role in formulating the notion of programming the Analytical Engine to perform different functions.
 - A. Blaise Pascal
 - B. Rene Descartes
 - C. [Ada Byron](#)
 - D. Joseph Jacquard
 - E. Gottfried Wilhelm von Leibniz

2. This person developed the first electro-mechanical tabulator, which read information from a punched card.
 - A. William Burroughs
 - B. [Herman Hollerith](#)
 - C. Alan Turing
 - D. John von Neumann
 - E. Thomas Watson

3. Which of the following characterizes the second generation (1959-1965) of computer hardware?
 - A. [Transistors](#)
 - B. Vacuum tubes
 - C. Silicon chips
 - D. Large-scale integration

4. Integrated Circuits characterize which generation of computer hardware?
 - A. first
 - B. second
 - C. [third](#)
 - D. fourth

5. In which computer software generation did the distinction between systems and application programmers first surface?
 - A. [first](#)
 - B. second
 - C. third
 - D. fourth
 - E. fifth

6. Which of the following concepts was introduced in the fourth generation (1971-1989) of computer software?
 - A. compiler
 - B. [structured programming](#)
 - C. time sharing
 - D. object-oriented design

7. A path that begins in the working directory is called a(n)
- A. absolute path
 - B. direct path
 - C. directory path
 - D. relative path
 - E. sequential path
8. Which of the following is true about dragging a file from one folder to another folder?
- A. the file will be moved, if the folders are on the same drive
 - B. the file will be copied, if the folders are on the different drives
 - C. both A and B
 - D. neither A nor B
9. The process of working with two or more applications at once is called
- A. multiprocessing
 - B. multitasking
 - C. multimanaging
 - D. multithreading
10. What do we call the Operating System's logical view of the files it manages?
- A. bit
 - B. byte
 - C. character
 - D. directory
 - E. file
 - F. file system
11. Files in which it is necessary that the data be accessed in a linear fashion from the beginning of the file to the end are called
- A. binary files
 - B. data files
 - C. direct access files
 - D. sequential files
 - E. text files
12. The smallest unit of storage in a computer is the
- A. byte
 - B. bit
 - C. character
 - D. digit

13. In a nanosecond, an electrical signal will travel approximately:
- A. 1 inch (3 cm)
 - B. 1 foot (30 cm)
 - C. 3 feet (1 m)
 - D. 1000 feet (300 m)
14. 1387 could be
- A. an octal number
 - B. a decimal number
 - C. a hexadecimal number
 - D. an octal or decimal number
 - E. a decimal or hexadecimal number
15. The unsigned decimal number 170 expressed in standard binary is
- A. 11001011
 - B. 10101111
 - C. 10101010
 - D. 111011
16. The decimal equivalent of 10010111 as an unsigned integer (natural number) is
- A. 106
 - B. 110
 - C. 150
 - D. -106
 - E. none of the above
17. The binary addition of (the unsigned numbers) $101110 + 11100 =$ _____.
- A. 1010100
 - B. 1001010
 - C. 11001
 - D. 1111000
18. The 8-bit two's complement representation of -60 is
- A. 00111100
 - B. 11000100
 - C. 11000011
 - D. 10111100

19. The 9-bit two's complement number 000010101 represents decimal
- A. -15
 - B. -21
 - C. 21
 - D. 15
20. The range of values that can be expressed in 8-bit two's complement is
- A. -256 to +256
 - B. -128 to +127
 - C. 0 to 255
 - D. -128 to +128
21. The decimal value of the fractional binary number 11.1001 is
- A. $3 \frac{9}{16}$
 - B. $-3 \frac{9}{16}$
 - C. $1 \frac{1}{4}$
 - D. $3 \frac{5}{8}$
22. If the binary fractional numbers 1001.111 and 11.111 are added the result, expressed as a decimal fraction is
- A. $-13 \frac{1}{4}$
 - B. $+13 \frac{1}{4}$
 - C. $+13 \frac{3}{4}$
 - D. $-13 \frac{3}{4}$
23. Moving the radix point 3 positions to the left in a binary fraction, the value of the fraction will be
- A. divided by 4
 - B. multiplied by 2
 - C. divided by 8
 - D. multiplied by 8
 - E. unchanged
24. The range, expressed in decimal, of 4-bit binary numbers in excess notation is
- A. 0 to 64
 - B. -32 to +32
 - C. -16 to +15
 - D. -8 to +7

25. Using 8 bits to store a normalized floating point number with the leftmost bit as the sign bit, the next 3 bits as the exponent (expressed in excess notation), followed by a 4-bit mantissa, the pattern 11101110 represents
- A. -1.5
 - B. 3.625
 - C. -7.9375
 - D. 3.25
 - E. -3.5
26. Using 8 bits to store a normalized floating point number with the leftmost bit as the sign bit, the next 3 bits as the exponent (expressed in excess notation), followed by a 4-bit mantissa, the decimal number $-15 \frac{3}{4}$ is represented by
- A. 11111111
 - B. 01111111
 - C. outside the allowed range
 - D. 01011100
27. Using 8 bits to store a normalized floating point number with the leftmost bit as the sign bit, the next 3 bits as the exponent (expressed in excess notation), followed by a 4-bit mantissa, which of the following is the best approximation to the decimal value .1 (one tenth).
- A. 00101000
 - B. 01100110
 - C. 00011101
 - D. 11000110
 - E. 00111000
28. Using 8 bits to store a normalized floating point number with the leftmost bit as the sign bit, the next 3 bits as the exponent (expressed in excess notation), followed by a 4-bit mantissa, what is the largest number greater than zero that can be represented?
- A. 3.75
 - B. 7.5
 - C. 15
 - D. there is no limit to the size
29. In Excess(128) notation, what proportion of the resulting bit patterns can be used to represent negative values?
- A. 1/10
 - B. 1/8
 - C. 1/4
 - D. 1/2
 - E. none of the above

30. The result of adding decimal values 5 and 4 in 4-bit two's complement notation is
- A. 9
 - B. the bit pattern 1001
 - C. the bit pattern 01001
 - D. truncation error
 - E. overflow error
31. Which of the following is the hexadecimal equivalent of the unsigned binary number 111000111?
- A. 303
 - B. 1C7
 - C. 347
 - D. E34
32. The notational system that represents any 4-bit pattern using a single character
- A. Unicode
 - B. ASCII code
 - C. Octal notation
 - D. Hexadecimal notation
33. If the binary number 1001001 represents the letter I in the ASCII table, what letter is represented by the binary number 1000110?
- A. H
 - B. F
 - C. G
 - D. f
 - E. g
34. How many bits would be needed to represent a character set containing 90 characters?
- A. 4
 - B. 5
 - C. 6
 - D. 7
 - E. 8
35. When the data being compressed consists of long sequences of the same value, which encoding system would be best?
- A. Keyword encoding
 - B. Run-length encoding
 - C. spatial compression
 - D. temporal compression

36. _____ uses a variable-length binary string to represent a character so that frequently used characters have short codes.
- A. Run-length encoding
 - B. Keyword encoding
 - C. Unicode encoding
 - D. Huffman encoding
37. _____ works best when used for video that changes little from frame to frame, such as a scene that contains little movement.
- A. Huffman encoding
 - B. keyword encoding
 - C. run length encoding
 - D. spatial compression
 - E. temporal compression
38. _____ often groups pixels into blocks (rectangular areas) that have the same colour, and then stores the colour and co-ordinates of the area.
- A. Huffman encoding
 - B. keyword encoding
 - C. run length encoding
 - D. spatial compression
 - E. temporal compression
39. An Excel cell range may consist of
- A. a single cell
 - B. a row or set of rows
 - C. a column or set of columns
 - D. all of the above
40. What gets pasted when you Copy a formula in a cell to the Clipboard and then Paste to another cell?
- A. All Formulas, Values, Formats, and Comments.
 - B. Formats only.
 - C. Values only.
 - D. Formulas only.
 - E. Comments only.

In questions 41 to 43, suppose that an Excel worksheet contains the formulas given as the Source. In each question, the contents of the cell indicated as the Source is copied (and pasted) to the cell indicated by the Result. What formula will appear in the Result cell after the copy/paste has been completed? Select the best answer.

*x. Source: K100 =Litre * Price / (100 * km) Result: L101 =

- A. Litre * Price / (100 * km)
- B. Litre * Price / (101 * km)
- C. #NA
- D. none of the above

*x. Source: C5 =MAX(B3:B6) Result: C3 =

- A. MAX(C1:C4)
- B. MAX(B1:C4)
- C. MAX(C3:C6)
- D. MAX(B1:B4)

*x. Source: B4 =B\$2 + \$A3 Result: E7 =

- A. B\$5 + \$D3
- B. E\$2 + \$A3
- C. E\$2 + \$A6
- D. E\$5 + \$D6

*44. Which of the following is true regarding Excel workbooks and worksheets

- A. a workbook contains one or more worksheets
- B. only one worksheet can be selected at a time within a workbook
- C. every workbook contains the same number of worksheets
- D. a formula cannot reference more than one workbook

45. What is the best way to enter December 20, 2005 into an Excel worksheet, given that you create the worksheet on that date, and further, that you always want to display that specific date?

- A. =TODAY()
- B. 12/20/05
- C. both A. and B. are equally acceptable
- D. neither A. nor B. will work

*46. A unique circuit diagram can be drawn for any truth table that shows the inputs and the output

- A. true
- B. false

47. Which of the following functions will return the highest and lowest values in a range of cells all containing numbers?

- A. HIGH/LOW
- B. LARGEST/SMALLEST
- C. MAX/MIN
- D. all of the above

This image shows a half adder implemented in Excel. The inputs are named **A** and **B**.

Numbers to add

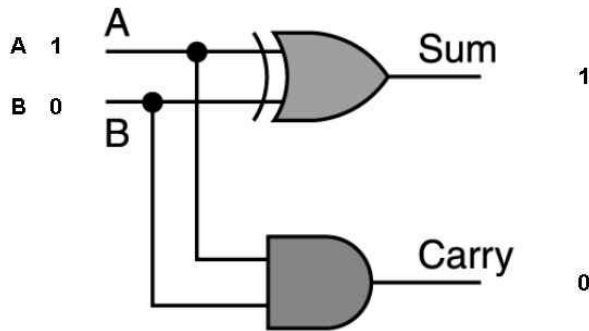

*48. Which of these formulas will calculate **Sum**?

- A. = AND (OR (A, B), NOT (AND (A, B)))
- B. = IF (AND (OR (A, B), NOT (AND (A, B))), 1, 0)
- C. = IF (XOR (A, B), 1, 0)
- D. = IF (XOR (A, B), "1", " 0")
- E. = XOR (A, B)

*49. Which of these formulas will calculate **Carry**?

- A. = AND (A, B)
- B. = IF (AND (A, B), 1, 0)
- C. = IF (OR (A, B), 1, 0)
- D. = NOT (NAND (A, B))
- E. = OR (A, B)

50. <new question>

- A.
- B.

A cell in an Excel worksheet contains the formula =NOW(). For each of the formats specified below, select the matching appearance of the data from this list:

- A. 38816 13/63
- B. 3881620.63%
- C. 38,816.21
- D. 3.88E+04
- E. 04/09
- F. 5:01:33

*51. Currency _____ C

*52. Fraction _____ A

*53. Scientific _____ D

*54. An S-R latch:

- A. can be constructed with 2 NAND gates
- B. is a sequential circuit
- C. the input values explicitly determine the output
- D. A and B are both true
- E. A, B and C are all true

*55. Choose the appropriate Boolean expression to represent the following circuit diagram.

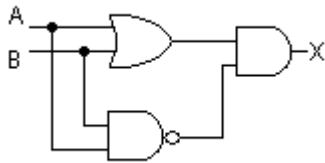

- A. $A+B \cdot (A' \cdot B')$
- B. $A \cdot B \oplus (A+B)$
- C. $(A \cdot B)' + (A+B)$
- D. $(A \cdot B)' \cdot (A \oplus B)$
- E. $A \oplus B$

*56. Two circuits are said to be equivalent if they produce the same output for each input value combination. Which of the following circuits are equivalent?

A

B

C

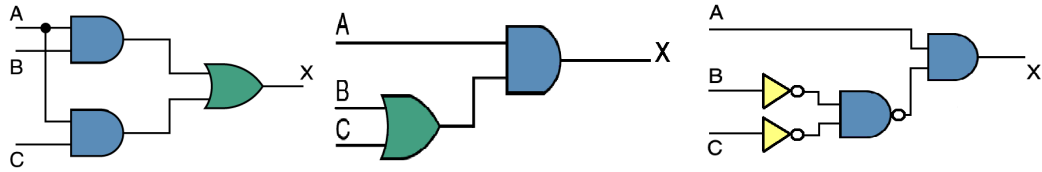

- A. A and B are equivalent
- B. A and C are equivalent
- C. B and C are equivalent
- D. all three are equivalent
- E. none are equivalent

From the list below, choose the Boolean expression that describes each of the following truth tables.

- A. $X = A'$
- B. $X = A \bullet B$
- C. $X = A \oplus B$
- D. $X = (A + B)'$
- E. $X = (A \bullet B)'$
- F. $X = A + B$
- G. $X = (A \oplus B)'$

A	B	X
0	0	1
0	1	0
1	0	0
1	1	0

*57.

Answer: _____ D

A	B	X
0	0	0
0	1	1
1	0	1
1	1	0

*58.

Answer: _____ C

A	B	X
0	0	0
0	1	0
1	0	0
1	1	1

*59.

Answer: _____ B

*60. Which gate does the following transistor diagram implement?

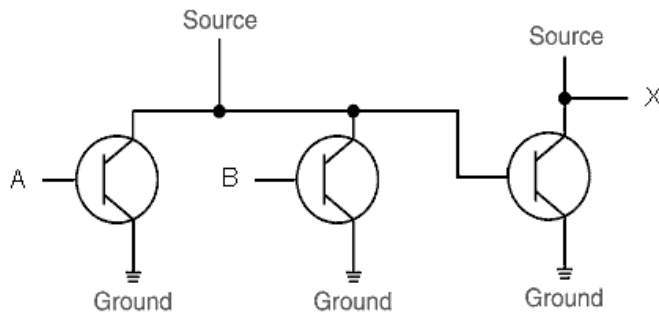

- A. AND
- B. NAND
- C. XOR
- D. OR
- E. NOR
- F. NOT

*61. $A \text{ and } (B \text{ or } C) = (A \text{ and } B) \text{ or } (A \text{ and } C)$ is an example of which of the following properties?

- A. Commutative
- B. Associative
- C. Distributive
- D. Identity
- E. Complement
- F. DeMorgan's Law

*62. The prefix *peta* refers to which power of ten?

- A. 10^{15}
- B. 10^{12}
- C. 10^9
- D. 10^6
- E. 10^3

For the next three questions, complete each of the following sentences by choosing the appropriate letter from the list of completions given below.

- A. ALU
- B. Bus
- C. Control Unit
- D. Instruction Register
- E. Main Memory
- F. Registers
- G. Program Counter

*x. A set of wires that connect all major sections of a machine through which data flows: _____. **B**

64. The component that holds the instruction currently being executed: _____. **D**

*x. The component from which the CPU accesses the needed programs and data: _____. **E**

66. For disk drives, the time it takes for a specified sector to move into position under the read/write head for reading is known as _____ time.

- A. transfer
- B. latency**
- C. access
- D. seek

67. Which of the following statements is FALSE?

- A. context switches require writing to a disk**
- B. context switches are managed by the Operating System
- C. context switches update CPU registers
- D. context switches allow other processes to run

68. Real-time Operating Systems

- A. require virtual memory
- B. require paged memory management
- C. have predictable response times**
- D. have fast response times

69. Which of the following statements is FALSE?

- A. pre-emptive scheduling is necessary for a time sharing system
- B. first-come, first-served produces optimal CPU scheduling for a time sharing system**
- C. round-robin scheduling requires time slices
- D. the turnaround time of a process in a time sharing system is dependent on others
- E. all of the above

70. This is a way of using the computer's hard disk as an extension of RAM.
- A. expanded memory
 - B. virtual memory
 - C. multithreading
 - D. interrupt request
71. When a typical computer first "boots", it starts executing instructions from:
- A. RAM
 - B. ROM
 - C. CD-ROM
 - D. a disk drive
 - E. a tape drive
72. Which Excel function will return "York" as a text value?.
- A. =RIGHT("York University",4)
 - B. =LEFT("York University",4)
 - C. = RIGHT("York University","York",4)
 - D. = LEFT("York University","York",4)
 - E. none of the above
73. Which Excel function converts a number as text to a numerical value, i.e. converts "123" to 123?
- A. NUMBER
 - B. CONVERT
 - C. VALUE
 - D. INTEGER
 - E. TEXT
- *74. A formula that takes into account the value of a preceding cell in its calculation (e.g. bank account balance) is referred to as a(n)
- A. cumulative function
 - B. occurrence formula
 - C. recurrence function
 - D. recurrence formula
 - E. recurring formula
- *75. _____ is defined as *developing a model of a complex system and experimenting with the model to observe the results.*
- A. What-if analysis
 - B. Simulation
 - C. Experimentation
 - D. Model Construction

76. The Thyroxine Conversion in the Liver problem is an example of

- A. discrete event simulation
- B. a queuing system
- C. concrete simulation
- D. continuous simulation

77. The peppermoth Population Model is an example of a Queuing System.

- A. true
- B. false

A table of data contains a column, named **StudentID**, of student numbers and a parallel column, named **Score**, of marks. For each of the next three questions, identify the formula that will perform the task specified.

*78. Find the lowest **Score** (named **Bottom**)

- A. = MAX(Score)
- B. = MEDIAN(Score)
- C. = MIN(Score)
- D. = MODE(Score)

*79. Determine if there is more than one occurrence of the **Bottom** Score.

- A. = COUNTIF(Score, Bottom)
- B. = IF(FIND(Bottom, Score) > 1, "Yes", "No")
- C. = IF(Score=Bottom, "Yes", "No")
- D. = MAX(Score - MODE(Score))

*XX. Determine the identity (the student number) of the student with the **Bottom** Score, assuming the **Bottom** Score is unique.

- A. = VLOOKUP(Bottom, Score, StudentID)
- B. = MATCH(Bottom, Score, 0)
- C. = LOOKUP(Bottom, Score, StudentID)
- D. = INDEX(StudentID, MATCH(Bottom, Score, 0))

The **Class** worksheet in the upper left has 3 columns of input data (**Name**, **Fac** and **Score**). **Grade** is produced by a formula. **GradeTable** worksheet (on the upper right) is the used to find the appropriate **Grade**. The top row of the **GradeTable** worksheet is named **Faculties**.

Name	Fac	Score	Grade	Faculties:	Arts	Science	Graduate
BERNIER	Arts	56	D+	0	F	F	F
BINCE	Arts	94	A+	40	E	F	F
BUSHBY	Arts	33	F	50	D	Pass	F
CAMPBELL	Science	55	C-	55	D+	C-	F
CORREIA	Graduate	66	Pass	60	C	C	Pass
CUKIER	Arts	80	A	65	C+	C+	Pass
DA-COSTA	Science	62	C	70	B	B-	C
DHILLON	Arts	88	A	75	B+	B	C
FERNANDES	Science	66	C+	80	A	B+	B
FRASER	Graduate	84	B	85	A	A-	B
GRAVAS	Graduate	95	A	90	A+	A	A
HALL	Science	48	F	95	A+	A+	A
HUNT	Arts	76	B+				
IVANOVA	Science	75	B				
JOHNSON	Science	75	B				
JOLLY	Arts	76	B+				
KALICHARAN	Arts	78	B+				
				Faculty	Arts	Science	Graduate
				Average Score	66.85714	65.23077	85.625
				Letter Grade	C+	C+	B

This example uses VLOOKUP and MATCH to find the appropriate Letter Grade for students in different faculties.
Table contains the GradeTable that lists thresholds and corresponding letter grades for 3 fictitious faculties.
Class contains a list of names, associated faculties, and scores on a campus-wide test.

*XX. Which of the following formulas finds the appropriate **Grade** for each **Score**, according to the student’s faculty (**Fac**)?

- A. =HLOOKUP(Fac,GradeTable,MATCH(Score,Faculties,0))
- B. =IF(Fac="Arts",LOOKUP(Score,Faculties,Arts),IF(Fac="Science",LOOKUP(Score,Faculties,Science),LOOKUP(Score,Faculties,Graduate)))
- C. =LOOKUP(Score,Faculties,MATCH(Fac,Faculties,0))
- D. =VLOOKUP(Score,Faculties,MATCH(Fac,Faculties,0))
- E. =VLOOKUP(Score,GradeTable,MATCH(Fac,Faculties,0))

The small sheet in the mid right position has been added to perform some analysis. Its top row is named **Faculty**.

*XX. Which of the following formulas finds the **Average Score** for each **Faculty**?

- A. =AVERAGE(MATCH(Fac,Faculties),Score)
- B. =AVERAGE(MATCH(Fac,Faculties,0),Score)
- C. =SUMIF(Fac,Faculties,Score)
- D. =SUMIF(Fac,Faculties,Score)/COUNTIF(Fac,Faculties)
- E. =SUMIF(MATCH(Fac,Faculties,0),Score)

Refer to the screenshots below to answer the next set of questions.

The table at the top is called **bioData**. It lists the songs on CBC’s National Top Ten Playlist, along with the Artist’s name and the Year the song was released. The row of titles is named **Titles**.

The bottom table is a summary. Labels (used to name the ranges) are in **bold** text. The rest is produced by formulas. The row of titles is named **criteria**.

SongTitle	Artist	Year	Votes
Lovers in a Dangerous Time	Bruce Cockburn	1984	1965
Bachelorette	Bjork	1997	2052
Under Pressure	Queen w/ David Bowie	1982	2007
Inside and Out	Feist	2004	2045
The Greatest	Cat Power	2006	2016
On the Hood	Matt Mays	2005	2047
When the Sun Goes Down	Arctic Monkeys	2006	2006
The Message	Grandmaster Flash and the Furious Five	1982	1961
Cartridge	Shawn Hewitt	2005	1987
The Big Guns	Jenny Lewis w/ The Watson Twins	2006	1981

	VotesCast	SongTitle	Artist	Year
most	2052	Lovers in a Dangerous Time	Bruce Cockburn	1984
least	1961	When the Sun Goes Down	Arctic Monkeys	2006

A third sheet (not shown) has a single column named **Ballots** which lists the Song Title on each vote that was made.

*XX. **Votes** is computed by counting the **Ballots**. What is it’s formula?

- A. =COUNT(Ballots,IF(SongTitle=SongTitle))
- B. =COUNTIF(Ballots,SongTitle)
- C. =COUNTIF(SongTitle,Ballots)
- D. =IF(Ballots=SongTitle,COUNT(SongTitle))
- E. =IF(SongTitle=Ballots,COUNT(Ballots))

*XX. Which of the folowing formulas computes **most VotesCast**?

- A. =COUNTIF(Ballots,SongTitle)
- B. =COUNTIF(Votes,MAX(Votes))
- C. =MAX(Votes)
- D. no formula is needed because of the “Use labels as references” option
- E. =SUM(Votes)

*XX. Which of these formulas is used to complete the rest of the Summary?

- A. =HLOOKUP(criteria,bioData,MATCH(VotesCast,Votes))
- B. =IF(AND(criteria=Titles,VotesCast=Votes),INDEX(bioData,))
- C. =INDEX(bioData,MATCH(VotesCast,Votes,0),MATCH(criteria,Titles,0))
- D. =LOOKUP(VotesCast,Votes,criteria)
- E. =VLOOKUP(VotesCast,bioData,MATCH(criteria,Titles,0))

86. A column in an Excel worksheet named **Letter Grade** contains the formula

=IF(Score>50,"D",IF(Score>60,"C",IF(Score>70,"B",IF(Score>80,"A","F"))))

What will appear in **Letter Grade** when **Score** is 55?

- A. A
- B. B
- C. C
- D. D
- E. F

87. Referring to the formula in the previous question, what will appear in **Letter Grade** when **Score** is 85?

- A. A
- B. B
- C. C
- D. D
- E. F

88. Which of the following expressions could NOT be the first argument in an Excel IF function?

- A. "A1 < C1"
- B. "A1" < "C1"
- C. A1 < C1
- D. ISEMPTY(A1)
- E. NOT(A1<C1)

89. A company decides to give some of its employees a holiday bonus. Those who have been employed at the company for at least 5 years get a bonus if their performance is considered either *good* or *excellent*. Those who have not been employed at the company that long get a bonus only if their performance is considered *excellent*. Assume the columns are named as shown.

Years	Rating	Bonus
3	excellent	YES
15	poor	NO
12	acceptable	NO
2	good	NO
10	good	YES

What formula could have been used to calculate the values in the **Bonus** column.

- A. =IF(Years>=5 AND (Rating="excellent" OR Rating="good"),"yes","no")
- B. =IF(Years>=5 AND (Rating="excellent" OR Rating="good"),"YES","NO")
- C. =IF(Years>=5 AND (Rating>="good"),"Yes","No")
- D. =IF(Rating="excellent","YES",IF(Rating="good",IF(Years>=5,"YES","NO")))
- E. =IF(OR(AND(Years>=5,OR(Rating="excellent",Rating="good")),Rating="excellent"),"YES","NO")

*90. Assume that all relevant ranges have been named according to their labels.

	E	F	G
14	Running Total		
15			
	Quantity	Ordered	
16	Ordered	to Date	
17	56	56	
18	20	76	
19	84	160	
20	72	232	
21	103	335	
22	40	375	
23			
24			

Referring to the screen shot of a Running Total worksheet above, which of the formulas below is best suited to be entered in cell F17 and autofilled down the column to F22?

- A. = Quantity_Ordered
- B. = SUM(Quantity_Ordered)
- C. = SUM(E17:E17)
- D. = SUM(\$E\$17:E17)
- E. = SUBTOTAL(Quantity_Ordered)

91. Excel's LOOKUP function is often used to replace the use of

- A. the FREQUENCY function
- B. the SUMIF function
- C. the COUNTIF function
- D. the IF function
- E. none of the above

*92. This is a field of study that involves efforts to endow computers with the ability to understand the meaning of human speech.

- A. virtual reality
- B. artificial intelligence
- C. ergonomics
- D. linguistics

*93. Searching all of the nodes on one level of a Search Tree before moving onto the next level is called:

- A. pruning
- B. depth-first approach
- C. breadth-first approach
- D. a semantic network

*94. The ambiguity that is created when words have multiple meanings is called

- A. Lexical ambiguity
- B. Positional ambiguity
- C. Referential ambiguity
- D. Semantic ambiguity
- E. Syntactic ambiguity

*95. Which of the following is **not** among the capabilities of computers?

- A. add a thousand four digit numbers quickly and easily
- B. draw complex three-dimensional images quickly and easily
- C. interpret a conversation quickly and easily
- D. navigate the surface of Mars without human intervention
- E. store and retrieve massive amounts of data quickly and easily

For the next 5 questions, match the terms that best fit the definitions below.

A. Inference engine	E. Semantic network
B. Knowledge-based system	F. Strong equivalence
C. Rule-based system	G. Training
D. Search tree	H. Weak equivalence

*96. The process of adjusting the weights and threshold values in an Artificial Neural Network to get a desired outcome.

Answer: _____ G

*97. The software that processes rules to draw conclusions.

Answer: _____ A

*98. A software system based on a set of *if-then* rules.

Answer: _____ C

*99. The equality of two systems based on their results and the process by which they arrive at those results.

Answer: _____ F

*100. A knowledge representation technique that represents the relationships among objects.

Answer: _____ E